

## “High-quality sound, Reproduce emotion”

JFSounds cable is aiming  
 “High-quality sound x duplicate emotion” design.  
 Expecting to have the emotion as you felt it live  
 in the concert.

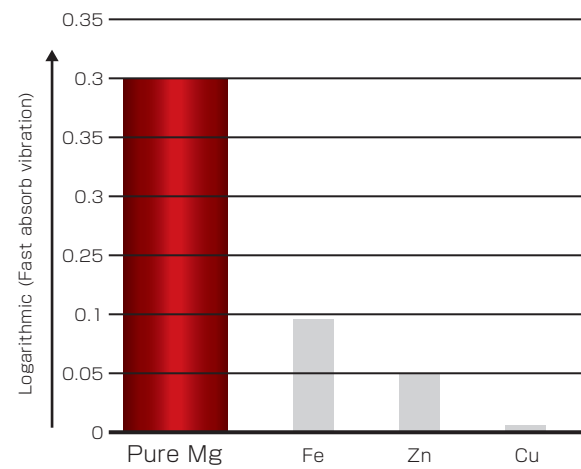

## “Overwhelming Vibration-damping”

JFSounds continue to develop the Audio Cable with  
 “Vibration damping” as a Key feature.  
 It is not well known, when Magnesium receives vibration, metal  
 crystals will move and change the vibration into heat energy.  
 Magnesium will also dampen the vibration.  
 Magnesium wire is used in the conductor cable directly and cable  
 itself will have inhibitory effect, which was proven.  
 Also targeted was the noise reduction effect with  
 new structure conductor.

## “Magnesium, Braided shield”

JFSounds have succeeded in making long length and  
 fine Magnesium alloyed wire.  
 By producing long length and fine sized wire, high shield  
 material Magnesium has managed to be used in the braided  
 shield process and  
 given success as a braided shield product.  
 This technology is top class in the world and  
 far ahead of all others.  
 JFSounds line cable has used  
 Magnesium alloy braided shield.



## Audio Line Cable STB27C Type/RCA

Using entire surface with Magnesium material for Original Model

### Characteristics

- Original technology from Speaker Cable MS227C was adopted.
- High-shielding was achieved by making the fine magnesium alloy wire braid, which was first in the industry.
- Plug area is expecting clearer quality sound to be possible with Rhodium-plating.
- By using hollow pipe, distance between conductor is separated and the capacitance is reduced.

### Specification

- Structure Conductor 2Core braided shield structure  
Cable Outer Dia:  $\phi$ 9.1mm
- Shield  $\phi$ 0.12mm Magnesium Alloy wire braid
- Conductor area Cu2.3sq Total 2.7sq.
- Conductor resistance 7.3m $\Omega$ /m
- Electrostatic capacity 137pF/m
- Plug Original RCA plug Material :Brass
- Plug processing Soldering
- Stabilizer Original Stabilizer Material :Brass  
Surface treatment:Rhodium-plated

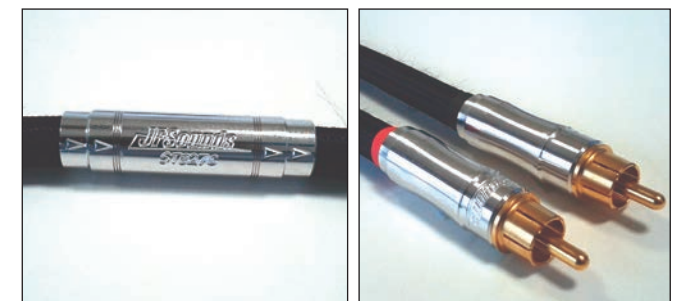
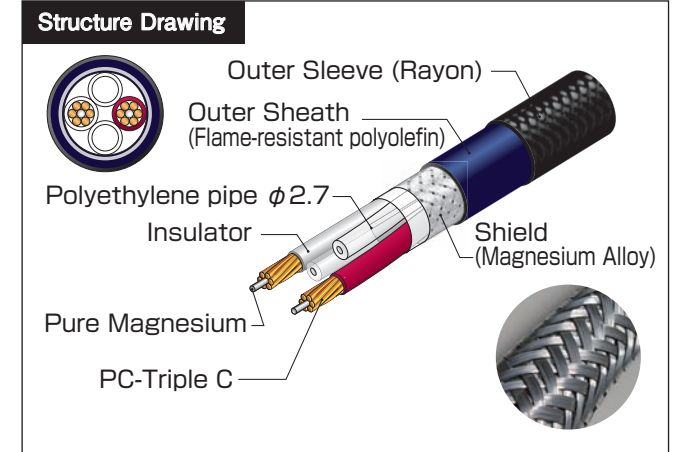

## Audio Line Cable STB27C-Plus Type/RCA

Targeted clear sound quality for High-End Model

### Characteristics

- Using very fine Magnesium alloy wire braid + Hybrid shield with Copper foil suitable for High-End model
- Plug “FURUTECH High-End / Grade RCA Plug FP-108( R )”
- Pure Magnesium Coil located inside and to pursue cable vibration suppression with original stabilizer.

### Specification

- Structure Conductor 2Core braided shield structure
- Shield  $\phi$ 0.12mm Magnesium Alloy wire braid · Copper foil
- Conductor area Cu2.3sq Total 2.7sq.
- Conductor resistance 7.6m $\Omega$ /m
- Electrostatic capacity 131pF/m
- Plug FURUTECH FP-108( R )  
Material / Center Pin:  $\alpha$  Conductor  
Body: Cover/Copper Alloy
- Plug processing By Screw
- Stabilizer Pure Magnesium Coiled Stabilier  
Material: Coil/Pure Magnesium  
Case: Brass

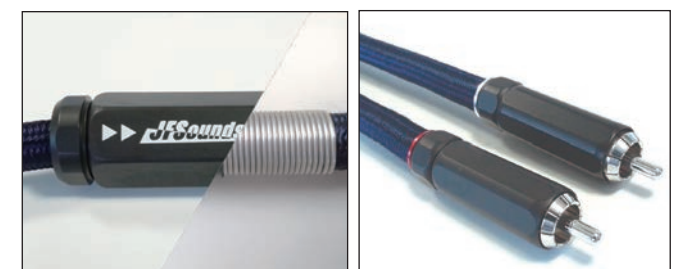
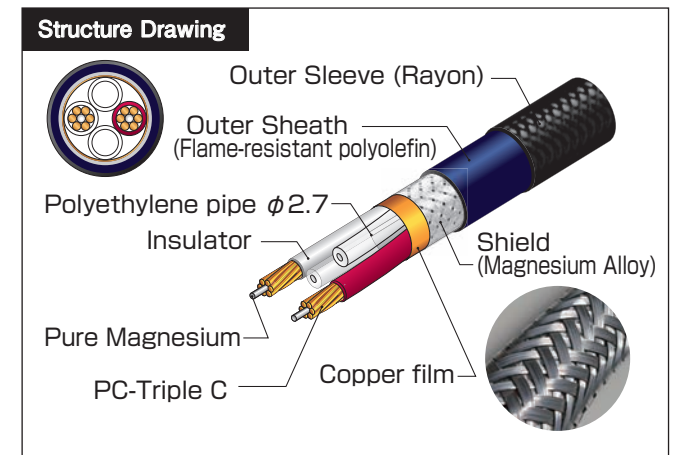

# Audio Speaker Cable MS227C

Magnesium Wire in the Core material  
New Idea: Speaker Cable

## Characteristics

- Using 99.5% pure magnesium wire in the core area to absorb vibration.
- PC-Triple C  $\phi 0.7\text{mm} \times 6$  stranded structured wire has been used.
- Using Polyethylene pipe material to reduce the capacitance and by reducing the capacitance it will reduce the transmission loss too.  
It is parallel structure.
- Polyethylene for insulator.

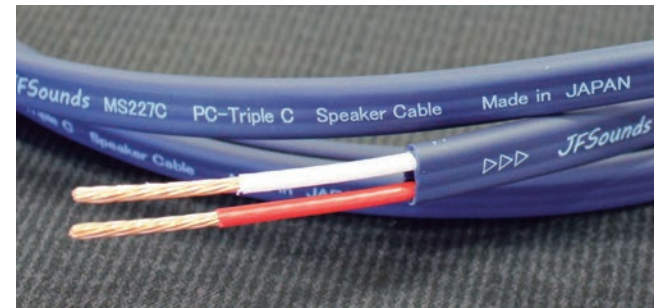

## Specification

- Structure 7 wire stranded with 2 parallel core wire
- Cable Outer Dia 4 × 10mm
- Conductor PC-Triple C 7  $\phi \times 6$  pcs
- Core Conductor Pure Magnesium 0.7  $\phi \times 1$  pcs
- Conductor Cross Section Cu2.3sq. Total 2.7sq
- Electrostatic capacity 36(pF/m)
- Conductor resistance 7.8(m $\Omega$ /m)

## Structure

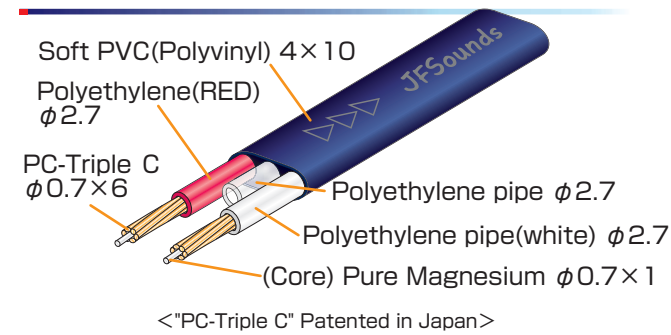

●Sales agent

●Contact

**Japan Fine Steel Co., Ltd.**  
*JFSounds*

19-1,ISHIIDE 1-CHOME  
SANYOONODA-SHI,YAMAGUCHI,756-0063  
JAPAN  
TEL:+81 (0)836-83-4982  
FAX:+81 (0)836-83-2953  
E-mail:jfsounds@jpfs.co.jp  
URL:http://www.jpfs.co.jp/  
facebook :https://www.facebook.com/jfsounds/



Audio Line Cable STB27C

Audio Line Cable STB27C-Plus

Audio Speaker Cable MS227C